

ZIGBEE CONTROL UNIT C4

70110022



Important: Read All Instructions Prior to Installation

Function introduction

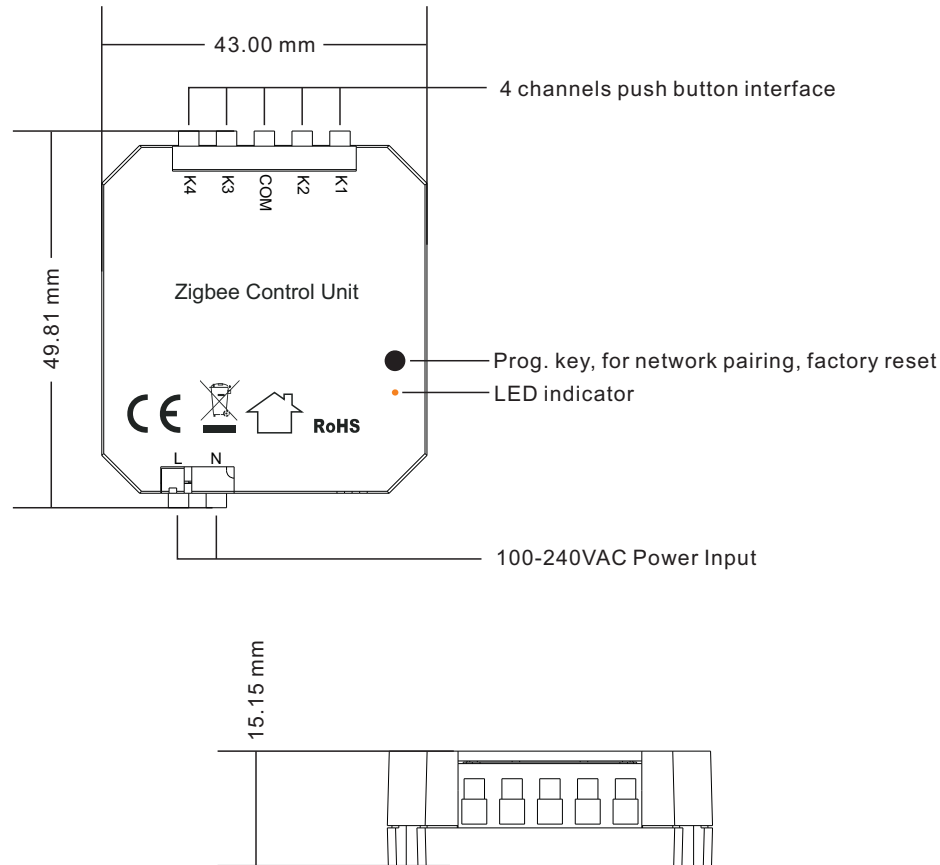

- Supports forming distributed security networks as router
- Three pre-configured Trust Center Link-Keys for joining:
 - Global Default Trust Center Link-)
 - Global Distributed Security Link-Key
 - Device-individual link-key derived from installation code
- Includes 128-bit installation code for secure joining (text and QR barcode)
- Extended neighbour table with up to 64 entries for routers and end-devices - more than 2 the capacity required by the standard (25)
- Extended routing table with up to 32 entries for ad hoc and many-to-one routes - more than 3 times the capacity required by the standard (10)
- Extended buffering for sleeping end-devices with up to 10 buffers - 10 times the capacity required by the standard (1)
- Extended APS duplicate rejection table with up to 30 slots - 30 times the capacity required by the standard (1)
- Extensive transmit and receive queues for optimum through-put and minimum packet drop rate
- Reliable and scalable network-wide broadcasts featuring passive acknowledgments
- Reliable packet forwarding with automatic network-level retries
- Very sophisticated routing algorithm for reliable ad hoc routing avoids routing loops even in case of concurrent route requests with overlapping source/destination
- Firmware upgradable over-the-air during normal operation using ZigBee OTA Upgrade Cluster
- Man-Machine-Interface: A push-button and a LED for network steering, factory reset etc.
- OEM and customized versions available upon request

Product Data

Transmission Range	10-30m (typical)
Radio Frequency	2.4GHz
Power Supply	100-240VAC, 50/60Hz
Power Consumption	Less than 0.3W
Number of Push Buttons	4
Connector Type	Push-In
Wire Size	0.2 - 1.5mm ² (AWG28 - AWG14)
Dimensions	49.8x43x15.1mm
Operating Temperature	-20 °C ~ +45 °C
Working Humidity	10% ~ 95% RH non-condensing
Waterproof Grade	IP20
Warranty	5 years

Features

- ZigBee Control Unit for up to four inputs with integrated ZigBee Router functionality
- Four configurable 230V~ inputs, can be individually set-up as on/off, level control, window covering controller and scene selector switches use with momentary or stationary switches
- Reliable, unattended, maintenance-free operation; designed for in-wall flush-mounting
- Made in China using high-quality, enduring parts for many years of life expectancy
- Low power dissipation: 0.3W
- Supports all channels in the 2.4 GHz band, i.e. channels 11-26 as per IEEE 802.15.4
 - Primary channel set = {11, 15, 20, 25 }
 - Secondary channel set = {12, 13, 14, 16, 17, 18, 19, 21, 22, 23, 24, 26 }
- Works under the ZigBee 3.0 common profile (former ZigBee Home Automation Profile ID)
- Supports joining centralized and distributed security networks as router
- Supports forming simple centralized security networks as Coordinator and Trust Center

Installation

1. Mains Powered Operation

Please refer to the hardware installation guide, which was included in the product package. It provides detailed installation instructions.

2. Low-Voltage Operation (Maintenance and Early System Integration Stages only)

Instead of applying dangerous mains voltage to the control unit C4, you may connect a low-voltage DC source (e.g. 24V=, 48V=) to the supply lines of C4. Its built-in universal power supply is able to operate from both kinds of supplies,

direct and alternating current. This can be useful during maintenance or early stages of system integration. In this mode, the ZigBee interface is operational and you can run OTA firmware upgrades, for example. However, the inputs are non-operational.

For DC operation (laboratory use), connect the DC ground (0V,"minus", negative) of your power supply to the neutral input of C4 (marked"N") and the DC supply voltage (24...48VDC,"plus",positive) to the phase input of C4 (marked"L"). Once powered, you should observe the normal device start-up behaviour (the green LED will flash a few times). If you are not using a safe low-voltage power-supply, utilizing the services of a professional installer/electrician is imperative.

Initial Device Start-up

The device will search for an open ZigBee network to join when you first apply power to it. Open the ZigBee network for joining and then power-up the device.

C4 will blink quickly to indicate a search in progress. Once a search cycle is complete it will either blink five times slowly to indicate it has joined a network, or blink three times quickly to indicate a joining failure-for example no network found, not permitted onto the network, etc. It will continue to search for a network in case of failure.

Subsequently, when the device is power-cycled, it will blink five times slowly to indicate it is operating as a router on the network, ten times slowly to indicate that it is operating as a coordinator and trust center or blink quickly to indicate it is searching for a network to join. When commissioned, the router's LED will remain off after the five/ten blink cycles during normal operation. Afterwards, it will turn on only for as long as it is permitting other devices to join the network.

After reboot, if the device is properly commissioned, it resumes operation doing a "silent rejoin", i.e. it does not broadcast a device announcement in this case. After joining a network, the device will prolong the joining window by three minutes via a fresh ZDO permit joining request.

Man-Machine Interface (MMI)

C4 offers a push-button behind a tiny hole in the front-face of the device, as well as a LED right next to it. This man-machine interface provides access to a menu.

To enter the menu, press and hold the push-button for more than a second until you see three short flashes followed by a sequence of one blink, pause, one blink, pause, etc. This indicates that you have successfully entered the menu. With each short button press (less than a second), you advance through the menu. For example, pressing the button once brings you to the second menu item, which C4 indicates by two blinks, pause, two blinks pause, etc. Once you have reached the menu item that you want to run, press and hold the button for more than a second to execute the selected item.

This is the menu for Control Unit C4:

Menu Item	Operation
1	ZigBee Commissioning: Network Steering While in this mode a single press on the button instigates ZigBee Network Steering ("EZ -mode"). If the device is on a network it will open the network for new devices for three minutes, otherwise it will attempt to join an open network.
2	ZigBee Commissioning: Finding & Binding Instigates the ZigBee Finding & Binding procedure ("EZ-mode") on an initiator or target endpoint. Target endpoints will enter identify mode for three minutes. Initiator endpoints will query targets and create suitable bindings to these targets. After leaving the menu in this mode, the first button press starts the selection of the endpoint and each subsequent press (within half a second) increments the endpoint number. Once the desired endpoint is reached, wait for the LED to blink the selected number of times. Then, press a single time to accept the selection or wait for three seconds to cancel the command. The LED will blink one time to confirm an affirmative choice, or two times to indicate the request has been cancelled.

3	ZigBee Commissioning: Clear Bindings Clears bindings on an initiator endpoint. Select this menu item and leave menu mode. Afterwards the device expects the selection of an initiator endpoint. The first button press starts the selection of the endpoint and each subsequent press (within half a second) increments the endpoint number. Once the desired endpoint is reached, wait for the LED to blink the selected number of times. Then, press a single time to accept the selection or wait for three seconds to cancel the command. The LED will blink one time to confirm an affirmative choice, or two times to indicate the request has been cancelled. This mode is active for one round only. Afterwards the device reverts to mode #1.
4	ZigBee Commissioning: Set Device Role and Factory Reset Selects the ZigBee device role for this device on the network, resets the remaining settings to factory defaults and restarts the device. Select this menu item and leave menu mode. Afterwards the device expects the selection of an option. The first button press starts the selection of the option and each subsequent press (within half a second) increments the option number. Once the desired option is reached, wait for the LED to blink the selected number of times. Then, press a single time to accept the selection or wait for three seconds to cancel the command. The LED will blink one time to confirm an affirmative choice, or two times to indicate the request has been cancelled. The following options are available: Option #1: Join an existing ZigBee network as router Option #2: Form a new distributed security network as the first router Option #3: Form a new centralized security network as the coordinator and trust center
5	Factory Reset Put the device into the same state as it was when it left the factory, then reboot. The only exception is the outgoing network security frame counter, which is preserved across factory resets.
6	ZigBee Commissioning: Advanced Commands Provides a number of advanced ZigBee commissioning command options. Select this menu item and leave menu mode. Afterwards the device expects the selection of an option. The first button press starts the selection of the option and each subsequent press (within half a second) increments the option number. Once the desired option is reached, wait for the LED to blink the selected number of times. Then, press a single time to accept the selection or wait for three seconds to cancel the command. The LED will blink one time to confirm an affirmative choice, or two times to indicate the request has been cancelled. The following options are available: Option #1: Perform a simple reset (reboot), then continue operating seamlessly (silent re-join) Option #2: Perform a simple reset (reboot), then re-join the network Option #3: Perform a full factory reset, including security frame counters and preserved settings
7	Reserved for internal use. Do not leave the menu in this mode.

ZigBee Interface

Please refer to the following IEEE and ZigBee Alliance documents, which apply to this product:

[R1] IEEE Standard 802-Part 15.4: Low-Rate Wireless Personal Area Networks (LR-WPANs) [R2] ZigBee Specification, Revision 20, Document No. 05-3474-20 [R3] ZigBee PRO/2007 Layer PICS and Stack Profiles, Revision 5, Document No. 08-0006-05 [R4] ZigBee Cluster Library Specification, Revision 4, Document No. 07-5123-04 [R5] ZigBee Home Automation Public Application Profile 1.2, Revision 29, Document No. 05-3520-29 [R6] ZigBee Smart Energy Standard 1.1b, Revision 18, Document No. 07-5356-18

Device Anatomy

The control unit C4 provides four high-voltage inputs for remote control of other on/off, level control and window covering target devices or groups. Being a mains-powered device, C4 also acts as a ZigBee router improving network connectivity and meshing capabilities as well as serving as a connection point ("parent") for sleeping end-devices.

C4 provides nine ZigBee application endpoints:

Endpoint	Profile	Application
0 (0x00)	0x0000: ZigBee Device Profile	ZigBee Device Object (ZDO)-standard management features
1 (0x01)	0x0104: Common Profile (HA)	Level Control Switch (0x0001). This endpoint is used to transmit on/off or level control commands triggered by any of the local high-voltage inputs.
2 (0x01)	0x0104: Common Profile (HA)	Level Control Switch (0x0001). This endpoint is used to transmit on/off or level control commands triggered by any of the local high-voltage inputs.
3 (0x02)	0x0104: Common Profile (HA)	Level Control Switch (0x0001). This endpoint is used to transmit on/off or level control commands triggered by any of the local high-voltage inputs.
4 (0x04)	0x0104: Common Profile (HA)	Level Control Switch (0x0001). This endpoint is used to transmit on/off or level control commands triggered by any of the local high-voltage inputs.
5 (0x05)	0x0104: Common Profile (HA)	Window Covering Controller (0x0203). This endpoint is used to transmit window covering commands triggered by any of the local high-voltage inputs.
6 (0x06)	0x0104: Common Profile (HA)	Window Covering Controller (0x0203). This endpoint is used to transmit window covering commands triggered by any of the local high-voltage inputs.
200 (0xC8)	Private	Private. This endpoint contains a legacy private application and provided for backwards-compatibility, only. This feature is deprecated and will be removed in a future firmware release after a grace period.
232 (0xE8)	0x0104: Common Profile (HA)	Device Management (0x0502)

1. Application Endpoint #0-ZigBee Device Object

Please refer to the ZigBee Specification [R2] for details on the ZigBee Device Object (ZDO) and the protocol used for over-the-air communication, called the ZigBee Device Profile (ZDP). Notice that the ZDP is fundamentally different from typical application endpoints, which build on the ZigBee foundation framework and the ZigBee Cluster Library (ZCL).

The ZigBee Control Unit C4 supports the following ZDO services:

Primitive	Description
nwk_addr_req/ nwk_addr_rsp	Network address request/response Translates a 64-bit IEEE address into a 16-bit network short address. Use only when really required, because this message employs a network-wide broadcast (flooding) and utilizes a large proportion of the available bandwidth.
ieee_addr_req/ ieee_addr_rsp	IEEE address request/response Translates a 16-bit network short address into a 64-bit IEEE address.
node_desc_req/ node_desc_rsp	Node descriptor request/response Returns information such as the manufacturer ID, power supply, etc.
active_ep_req/ active_ep_rsp	Active endpoints request/response Returns a set of available application endpoints on the device.

simple_desc_req/ simple_desc_rsp	Simple descriptor request/response Returns a descriptor for a certain application endpoint with a list of available services (clusters).
match_desc_req/ match_desc_rsp	Match descriptor request/response Searches for a certain cluster or set of clusters and returns the matching endpoints, if any.
device_annce	Device announcement Advertises the presence of a new device in the network.
bind_req/ bind_rsp	Bind request/response Creates an application binding
unbind_req/ unbind_rsp	Unbind request/response Removes an application binding
mgmt_lqi_req/ mgmt_lqi_rsp	Management: Neighbor table request/response Returns information about neighboring devices, including the link quality, device type etc.
mgmt_rtg_req/ mgmt_rtg_rsp	Management: Routing table request/response Returns information about routes established on the device.
mgmt_bind_req/ mgmt_bind_rsp	Management: Binding table request/response Returns information about application bindings on the device.
mgmt_leave_req/ mgmt_leave_rsp	Management: Leave request/response Makes the device leave the network or removes one of its end-device children.
mgmt_permit_joining_req/ mgmt_permit_joining_rsp	Management: Permit joining request/response Opens the network for new devices to join.

2. Application Endpoint #1-Primary Level Control Switch

This is a Finding & Binding initiator endpoint.

2.1. Basic Cluster (Server)

Please refer to section 8.1 for details.

2.2. Identify Cluster (Server)

Notice: The identify cluster instance on this endpoint does not provide any visual or audible feedback. It is mainly present to comply with standards requirements.

Attributes supported:

Attribute	Type	Description
0x0000	unsigned16	IdentifyTime The remaining time, in seconds, the device will be identifying itself. Notice that C4 currently does not provide any visual feedback in identify mode.

Cluster commands supported:

Command	Description
0x0000	Identify Puts the device into identify mode, or terminates identify mode.
0x0001	Query Identify Determines whether the device is currently identifying, and returns the remaining time if so.

2.3. Scenes Cluster (Client)

Notice: This cluster does not use the binding table for managing command targets. Instead, recall scene command templates include the group address and scene number to recall. The device setup cluster on the Device Management endpoint can be used to configure the behavior of the cluster, i.e. which identifiers will be sent in the message body, when the input state changes. Using the device setup cluster, you can configure this endpoint either to be used with a push-button or a switch.

This cluster instance is intended for recalling scenes on the local and/or remote devices using the local inputs and is not bound when factory fresh.

Cluster commands transmitted:

Command	Description
0x0005	Recall Scene Recalls a scene. The group address in the recall scene command payload is also used as the target for the command.

2.4. On/off Cluster (Client)

Notice: This cluster uses the binding table for managing command targets. In addition, the device setup cluster on the Device Management endpoint can be used to configure the behavior of the cluster, i.e. which of the commands mentioned below will actually be sent, when the input state changes. Using the device setup cluster, you can configure this endpoint either to be used with a push-button (momentary switch, one stable position) or a rocker switch (two stable positions).

Cluster commands transmitted:

Command	Description
0x0000	Turn off Turns the target device or group of devices off.
0x0001	Turn on Turns the target device or group of devices on.
0x0002	Toggle Toggles the target device state. Should not be used to control groups.

2.5. Level Control Cluster (Client)

Notice: This cluster uses the binding table for managing command targets. In addition, the device setup cluster on the Device Management endpoint can be used to configure the behavior of the cluster, i.e. which of the commands mentioned below will actually be sent, when the input state changes. Using the device setup cluster, you can configure this endpoint either to be used with one or two push-buttons.

Cluster commands transmitted:

Command	Description
0x0005	Move with on/off Moves the level either up or down at a specified rate. Maintains the companion on/off cluster's OnOff attribute.
0x0007	Stop with on/off Stops any level change in progress due to a move, move to level, step or recall scene command. Maintains the companion on/off cluster's OnOff attribute.

3. Application Endpoint #2-Secondary Level Control Switch

This is a Finding & Binding initiator endpoint.

3.1. Basic Cluster (Server)

Please refer to section 8.1 for details.

3.2. Identify Cluster (Server)

Notice: The identify cluster instance on this endpoint does not provide any visual or audible feedback. It is mainly present to comply with standards requirements.

Attributes supported:

Attribute	Type	Description
0x0000	unsigned16	IdentifyTime The remaining time, in seconds, the device will be identifying itself. Notice that C4 currently does not provide any visual feedback in identify mode.

Cluster commands supported:

Command	Description
0x0000	Identify Puts the device into identify mode, or terminates identify mode.
0x0001	Query Identify Determines whether the device is currently identifying, and returns the remaining time if so.

3.3. Scenes Cluster (Client)

Notice: This cluster does not use the binding table for managing command targets. Instead, recall scene command templates include the group address and scene number to recall. The device setup cluster on the Device Management endpoint can be used to configure the behavior of the cluster, i.e. which identifiers will be sent in the message body, when the input state changes. Using the device setup cluster, you can configure this endpoint either to be used with a push-button or a switch.

This cluster instance is intended for recalling scenes on the local and/or remote devices using the local inputs and is not bound when factory fresh.

Cluster commands transmitted:

Command	Description
0x0005	Recall Scene Recalls a scene. The group address in the recall scene command payload is also used as the target for the command.

3.4. On/off Cluster (Client)

Notice: This cluster uses the binding table for managing command targets. In addition, the device setup cluster on the Device Management endpoint can be used to configure the behavior of the cluster, i.e. which of the commands mentioned below will actually be sent, when the input state changes. Using the device setup cluster, you can configure this endpoint either to be used with a push-button (momentary switch, one stable position) or a rocker switch (two stable positions).

Cluster commands transmitted:

Command	Description
0x0000	Turn off Turns the target device or group of devices off.
0x0001	Turn on Turns the target device or group of devices on.
0x0002	Toggle Toggles the target device state. Should not be used to control groups.

3.5. Level Control Cluster (Client)

Notice: This cluster uses the binding table for managing command targets. In addition, the device setup cluster on the Device Management endpoint can be used to configure the behavior of the cluster, i.e. which of the commands mentioned below will actually be sent, when the input state changes. Using the device setup cluster, you can configure this endpoint either to be used with one or two push-buttons.

Cluster commands transmitted:

Command	Description
0x0005	Move with on/off Moves the level either up or down at a specified rate. Maintains the companion on/off cluster's OnOff attribute.
0x0007	Stop with on/off Stops any level change in progress due to a move, move to level, step or recall scene command. Maintains the companion on/off cluster's OnOff attribute.

4. Application Endpoint #3-Tertiary Level Control Switch

This is a Finding & Binding initiator endpoint.

4.1. Basic Cluster (Server)

Please refer to section 8.1 for details.

4.2. Identify Cluster (Server)

Notice: The identify cluster instance on this endpoint does not provide any visual or audible feedback. It is mainly present to comply with standards requirements.

Attributes supported:

Attribute	Type	Description
0x0000	unsigned16	IdentifyTime The remaining time, in seconds, the device will be identifying itself. Notice that C4 currently does not provide any visual feedback in identify mode.

Cluster commands supported:

Command	Description
0x0000	Identify Puts the device into identify mode, or terminates identify mode.
0x0001	Query Identify Determines whether the device is currently identifying, and returns the remaining time if so.

4.3. Scenes Cluster (Client)

Notice: This cluster does not use the binding table for managing command targets. Instead, recall scene command templates include the group address and scene number to recall. The device setup cluster on the Device Management endpoint can be used to configure the behavior of the cluster, i.e. which identifiers will be sent in the message body, when the input state changes. Using the device setup cluster, you can configure this endpoint either to be used with a push-button or a switch.

This cluster instance is intended for recalling scenes on the local and/or remote devices using the local inputs and is not bound when factory fresh.

Cluster commands transmitted:

Command	Description
0x0005	Recall Scene Recalls a scene. The group address in the recall scene command payload is also used as the target for the command.

4.4. On/off Cluster (Client)

Notice: This cluster uses the binding table for managing command targets. In addition, the device setup cluster on the Device Management endpoint can be used to configure the behavior of the cluster, i.e. which of the commands mentioned below will actually be sent, when the input state changes. Using the device setup cluster, you can configure this endpoint either to be used with a push-button (momentary switch, one stable position) or a rocker switch (two stable positions).

Cluster commands transmitted:

Command	Description
0x0000	Turn off Turns the target device or group of devices off.
0x0001	Turn on Turns the target device or group of devices on.
0x0002	Toggle Toggles the target device state. Should not be used to control groups.

4.5. Level Control Cluster (Client)

Notice: This cluster uses the binding table for managing command targets. In addition, the device setup cluster on the Device Management endpoint can be used to configure the behavior of the cluster, i.e. which of the commands mentioned below will actually be sent, when the input state changes. Using the device setup cluster, you can configure this endpoint either to be used with one or two push-buttons.

Cluster commands transmitted:

Command	Description
0x0005	Move with on/off Moves the level either up or down at a specified rate. Maintains the companion on/off cluster's OnOff attribute.
0x0007	Stop with on/off Stops any level change in progress due to a move, move to level, step or recall scene command. Maintains the companion on/off cluster's OnOff attribute.

5. Application Endpoint #4-Quaternary Level Control Switch

This is a Finding & Binding initiator endpoint.

5.1. Basic Cluster (Server)

Please refer to section 8.1 for details.

5.2. Identify Cluster (Server)

Notice: The identify cluster instance on this endpoint does not provide any visual or audible feedback. It is mainly present to comply with standards requirements.

Attributes supported:

Attribute	Type	Description
0x0000	unsigned16	IdentifyTime The remaining time, in seconds, the device will be identifying itself. Notice that C4 currently does not provide any visual feedback in identify mode.

Cluster commands supported:

Command	Description
0x0000	Identify Puts the device into identify mode, or terminates identify mode.
0x0001	Query Identify Determines whether the device is currently identifying, and returns the remaining time if so.

5.3. Scenes Cluster (Client)

Notice: This cluster does not use the binding table for managing command targets. Instead, recall scene command templates include the group address and scene number to recall. The device setup cluster on the Device Management endpoint can be used to configure the behavior of the cluster, i.e. which identifiers will be sent in the message body, when the input state changes. Using the device setup cluster, you can configure this endpoint either to be used with a push-button or a switch.

This cluster instance is intended for recalling scenes on the local and/or remote devices using the local inputs and is not bound when factory fresh.

Cluster commands transmitted:

Command	Description
0x0005	Recall Scene Recalls a scene. The group address in the recall scene command payload is also used as the target for the command.

5.4. On/off Cluster (Client)

Notice: This cluster uses the binding table for managing command targets. In addition, the device setup cluster on the Device Management endpoint can be used to configure the behavior of the cluster, i.e. which of the commands mentioned below will actually be sent, when the input state changes. Using the device setup cluster, you can configure this endpoint either to be used with a push-button (momentary switch, one stable position) or a rocker switch (two stable positions).

Cluster commands transmitted:

Command	Description
0x0000	Turn off Turns the target device or group of devices off.
0x0001	Turn on Turns the target device or group of devices on.
0x0002	Toggle Toggles the target device state. Should not be used to control groups.

5.5. Level Control Cluster (Client)

Notice: This cluster uses the binding table for managing command targets. In addition, the device setup cluster on the Device Management endpoint can be used to configure the behavior of the cluster, i.e. which of the commands mentioned below will actually be sent, when the input state changes. Using the device setup cluster, you can configure this endpoint either to be used with one or two push-buttons.

Cluster commands transmitted:

Command	Description
0x0005	Move with on/off Moves the level either up or down at a specified rate. Maintains the companion on/off cluster's OnOff attribute.
0x0007	Stop with on/off Stops any level change in progress due to a move, move to level, step or recall scene command. Maintains the companion on/off cluster's OnOff attribute.

6. Application Endpoint #5-Primary Window Covering Controller

This is a Finding & Binding initiator endpoint.

6.1. Basic Cluster (Server)

Please refer to section 8.1 for details.

6.2. Identify Cluster (Server)

Notice: The identify cluster instance on this endpoint does not provide any visual or audible feedback. It is mainly present to comply with standards requirements.

Attributes supported:

Attribute	Type	Description
0x0000	unsigned16	IdentifyTime The remaining time, in seconds, the device will be identifying itself. Notice that C4 currently does not provide any visual feedback in identify mode.

Cluster commands supported:

Command	Description
0x0000	Identify Puts the device into identify mode, or terminates identify mode.
0x0001	Query Identify Determines whether the device is currently identifying, and returns the remaining time if so.

6.3. Scenes Cluster (Client)

Notice: This cluster does not use the binding table for managing command targets. Instead, recall scene command templates include the group address and scene number to recall. The device setup cluster on the Device Management endpoint can be used to configure the behavior of the cluster, i.e. which identifiers will be sent in the message body, when the input state changes. Using the device setup cluster, you can configure this endpoint either to be used with a push-button or a switch.

This cluster instance is intended for recalling scenes on the local and/or remote devices using the local inputs and is not bound when factory fresh.

Cluster commands transmitted:

Command	Description
0x0005	Recall Scene Recalls a scene. The group address in the recall scene command payload is also used as the target for the command.

6.4. Window Covering Cluster (Client)

Notice: This cluster uses the binding table for managing command targets. In addition, the device setup cluster on the Device Management endpoint can be used to configure the behavior of the cluster, i.e. which of the commands mentioned below will actually be sent, when the input state changes. Using the device setup cluster, you can configure this endpoint either to be used with two push-buttons (momentary switches, one stable position) or two rocker switches (two stable positions).

Cluster commands transmitted:

Command	Description
0x0000	Move up/open Makes the target device or group of devices move up, towards the fully open position.
0x0001	Move down/close Makes the target device or group of devices move down, towards the fully closed position.
0x0002	Stop Stops all motion.

7. Application Endpoint #6-Secondary Window Covering Controller

This is a Finding & Binding initiator endpoint.

7.1. Basic Cluster (Server)

Please refer to section 8.1 for details.

7.2. Identify Cluster (Server)

Notice: The identify cluster instance on this endpoint does not provide any visual or audible feedback. It is mainly present to comply with standards requirements.

Attributes supported:

Attribute	Type	Description
0x0000	unsigned16	IdentifyTime The remaining time, in seconds, the device will be identifying itself. Notice that C4 currently does not provide any visual feedback in identify mode.

Cluster commands supported:

Command	Description
0x0000	Identify Puts the device into identify mode, or terminates identify mode.
0x0001	Query Identify Determines whether the device is currently identifying, and returns the remaining time if so.

7.3. Scenes Cluster (Client)

Notice: This cluster does not use the binding table for managing command targets. Instead, recall scene command templates include the group address and scene number to recall. The device setup cluster on the Device Management endpoint can be used to configure the behavior of the cluster, i.e. which identifiers will be sent in the message body, when the input state changes. Using the device setup cluster, you can configure this endpoint either to be used with a push-button or a switch.

This cluster instance is intended for recalling scenes on the local and/or remote devices using the local inputs and is not bound when factory fresh.

Cluster commands transmitted:

Command	Description
0x0005	Recall Scene Recalls a scene. The group address in the recall scene command payload is also used as the target for the command.

7.4. Window Covering Cluster (Client)

Notice: This cluster uses the binding table for managing command targets. In addition, the device setup cluster on the Device Management endpoint can be used to configure the behavior of the cluster, i.e. which of the commands mentioned below will actually be sent, when the input state changes. Using the device setup cluster, you can configure this endpoint either to be used with two push-buttons (momentary switches, one stable position) or two rocker switches (two stable positions).

Cluster commands transmitted:

Command	Description
0x0000	Move up/open Makes the target device or group of devices move up, towards the fully open position.
0x0001	Move down/close Makes the target device or group of devices move down, towards the fully closed position.
0x0002	Stop Stops all motion.

8. Application Endpoint #232 Device Management

This endpoint provides device management functions using standard ZigBee foundation paradigms and the ZigBee Cluster Library [R4]. You may use the standard ZCL frames to enumerate, read and write attributes, configure attribute reporting, invoke commands, etc.

The application endpoint exposes the following clusters:

Cluster	Direction	Description
0x0000	Inbound (Server)	Basic Provides basic information about the device, such as the manufacturer ID, vendor and model name, stack profile, ZCL version, production date, hardware revision etc. Allows a factory reset of attributes, without the device leaving the network.
0x0003	Outbound (Client)	Identify Allows to identify targets during Finding & Binding push-button commissioning.
0x0015	Inbound (Server)	Commissioning Offers fine-grained commissioning options, for example, configuring a certain short address, channel mask, concentrator setup etc. This cluster is rarely used.
0x0019	Outbound (Client)	OTA Upgrade Pull-oriented firmware upgrade. Searches the network for mating servers and allows the server to control all stages of the upgrade process, including which image to download, when to download, at what rate and when to install the downloaded image.
0xFC00	Inbound (Server)	Device Setup This is a manufacturer-specific cluster used for basic device setup. For example, it can be used to assign physical inputs to endpoints and to control the behaviour of inputs (i.e. permanent switches, push-button switches, normally open vs. normally closed, on/off, level control or scene selection, etc.)

8.1. Basic Cluster (Server)

The basic cluster might be accessible via more than one endpoint. Most of its attributes are singleton attributes, i.e. all instances of the cluster share the same attribute value storage.

Attributes supported:

Attribute	Type	Description
0x0000	unsigned8, read-only	ZCLVersion The version of the cluster library
0x0001	unsigned8, read-only	ApplicationVersion The application version
0x0002	unsigned8, read-only	StackVersion The stack version
0x0003	unsigned8, read-only	HWVersion Specifies the hardware revision number
0x0004	string, read-only	ManufacturerName "Sunricher"
0x0005	string, read-only	ModelIdentifier "ZG2833PAC"
0x0006	string, read-only	DateCode "Null"
0x0007	enum8, read-only	PowerSource Always set to mains-powered, single phase (regardless of the connected supply voltage)
0x0008	enum8, read-only	GenericDeviceClass The generic device class
0x0009	enum8, read-only	GenericDeviceType The generic device type

0x000A	enum8, read-only	ProductCode The product code
0x000B	string, persistent	ProductUrl The product url
0x0010	string, persistent	LocationDescription Empty string by default. Might be set by commissioning software during installation
0x0011	unsigned8, persistent	PhysicalEnvironment "Unspecified" by default. Might be set by commissioning software during installation
0x4000	unsigned8, persistent	SWBuildID The software build ID

Cluster commands supported:

Command	Description
0x0000	Reset to factory defaults. Restores the values of all attributes of all clusters across all endpoints to their factory fresh default settings. Does not affect network settings or bindings. Notice: In the current version, the command does actually behave like a leave command with factory reset. This will be fixed in a future release.

8.2. Identify Cluster (Client)

The client side of the identify cluster on this endpoint is used for push-button commissioning.

Cluster commands transmitted:

Command	Description
0x0001	Query Identify This command is broadcast during push-button commissioning to identify suitable binding targets. Once target devices are selected, they will be queried for matching descriptors.

8.3. Commissioning Cluster (Server)

This implementation supports all attributes and most commands. However, the cluster has limited value. It is rarely used and might be removed in the future.

8.4. Over-the-Air Upgrade Cluster (Client)

The image type for C4 is 0x7B09. You may request the latest firmware in ZigBee OTA image format to upgrade devices in the field using your own OTA server and back-end.

8.5. Device Setup Cluster (Server)

This cluster is manufacturer-specific and allows to change advanced device setup options, which are not covered by standard clusters defined in the ZigBee Cluster Library.

Attributes supported:

Attribute	Type	Description
0x0000	array of data8, persistent	InputConfigurations This array of 8-bit data holds exactly one entry per physical device input and allows disabling the input or inverting the "normal" signal level (normally closed vs. normally open).

0x0001	array of raw data, persistent	<p>InputActions</p> <p>This array of raw data strings maps physical inputs to application endpoints on the device (for example, an on/off switch application) and translates level changes to appropriate cluster commands (e.g. on/off/toggle or move/stop).</p>
0x0010	array of data8, persistent	<p>InputConfigurations Key1</p> <p>In order to solve the problem of using one attribute configuration for the four buttons to send packets, which will cause the data content of the configuration packet to be too long, this attribute is only used to configure the packet data of key 1. The data protocol is exactly the same as that of InputConfigurations, and the original attribute InputConfigurations remains.</p> <p>When the "element count" in this attribute is not equal to 0, operation key 1 uses the content of this attribute to send the packet;</p> <p>When the "element count" in this attribute is equal to 0, operation key 1 uses the content of the InputConfigurations attribute to send the packet;</p> <p>Configuration example: 100048410300 09000d01050005010001 09000201050005010001 09000301050005010002</p>
0x0011	array of data8, persistent	<p>InputConfigurations Key2</p> <p>In order to solve the problem of using one attribute configuration for the four buttons to send packets, which will cause the data content of the configuration packet to be too long, this attribute is only used to configure the packet data of key 2. The data protocol is exactly the same as that of InputConfigurations, and the original attribute InputConfigurations remains.</p> <p>When the "element count" in this attribute is not equal to 0, operation key 2 uses the content of this attribute to send the packet;</p> <p>When the "element count" in this attribute is equal to 0, operation key 2 uses the content of the InputConfigurations attribute to send the packet;</p> <p>Configuration example: 110048410300 09010d02050005010001 09010202050005010001 09010302050005010002</p>
0x0012	array of data8, persistent	<p>InputConfigurations Key3</p> <p>In order to solve the problem of using one attribute configuration for the four buttons to send packets, which will cause the data content of the configuration packet to be too long, this attribute is only used to configure the packet data of key 3. The data protocol is exactly the same as that of InputConfigurations, and the original attribute InputConfigurations remains.</p> <p>When the "element count" in this attribute is not equal to 0, operation key 3 uses the content of this attribute to send the packet;</p> <p>When the "element count" in this attribute is equal to 0, operation key 3 uses the content of the InputConfigurations attribute to send the packet;</p> <p>Configuration example: 120048410300 09020d03050005010001 09020203050005010001 09020303050005010002</p>

0x0013	array of data8, persistent	<p>InputConfigurations Key4</p> <p>In order to solve the problem of using one attribute configuration for the four buttons to send packets, which will cause the data content of the configuration packet to be too long, this attribute is only used to configure the packet data of key 4. The data protocol is exactly the same as that of InputConfigurations, and the original attribute InputConfigurations remains.</p> <p>When the "element count" in this attribute is not equal to 0, operation key 4 uses the content of this attribute to send the packet;</p> <p>When the "element count" in this attribute is equal to 0, operation key 4 uses the content of the InputConfigurations attribute to send the packet;</p> <p>Configuration example: 130048410300 09030d04050005010001 09030204050005010001 09030304050005010002</p>
--------	----------------------------	--

8.5.1. InputConfigurations Attribute

This attribute is an array (ZCL data type 0x48) of 8-bit data (ZCL data type 0x08). It is readable and writable and retains its value across reboots (persistent storage); when written the size of the attribute is not allowed to change, and the elements mu-(0x08). Each physical device input line has a one-to-one relation to a slot in this array.

For C4 this relation is as follows:

Element	Description
0x0000	Configuration options for high-voltage physical input #1 Defines the configuration for the physical input marked with a switch symbol and the digit"1". Factory default value: 0x00
0x0001	Configuration options for high-voltage physical input #2 Defines the configuration for the physical input marked with a switch symbol and the digit"2" Factory default value: 0x00
0x0002	Configuration options for high-voltage physical input #3 Defines the configuration for the physical input marked with a switch symbol and the digit"3" Factory default value: 0x00
0x0003	Configuration options for high-voltage physical input #4 Defines the configuration for the physical input marked with a switch symbol and the digit"4" Factory default value: 0x00

Each element can take a combination of the following bit flags:

Flag	Bit(s)	Description
Disable	#7 (0x80)	When this bit is set, the input is disabled.
RFU	#5... #0 (0x3F)	All other bits are reserved for future use and must be written as 0 and ignored when read.

8.5.2. InputActions Attribute

This attribute is an array (ZCL data type 0x48) of raw binary data (ZCL data type 0x41). It is readable and writable and retains its value across reboots (persistent storage); when written, the elements must be of the same type"raw data." (0x4 1).

This attribute contains instructions, a kind of micro-code, which allow flexible reconfiguration of the commands sent in response to activity on the physical inputs.

Each element can take a combination of the following bit flags:

Field	Data Type	Description
InputAndOptions	unsigned8	A four-bit input index in the LSBs and four option flags in the MSBs.
Transition	unsigned8	Specifies the level transition to which this particular instruction applies.
Endpoint	unsigned8	Each instruction must be assigned to a suitable source endpoint in the local device. Acceptable endpoints for C4: Endpoints #1, #2, #3, #4, #5 and #6.
ClusterID	unsigned16	The 16-bit cluster ID that will be used to transmit the ZCL command payload, e.g. 0x0006 for the on/off cluster, 0x0008 for level control, etc.
CommandTemplate	raw data	A variable length ZCL command template, which will be sent from the source endpoint specified above, using the cluster ID specified above. This can be a simple off (0x00), on (0x01) or toggle (0x02) command, or more complex commands. There might be code in the device that modifies the command template according to intrinsic rules or option flag settings. Notice that this is the raw payload and does not include a leading length byte.

InputAndOptions

This field contains the physical input number in the lower four bits and indexes into the InputConfigurations array. For example, a value of 0 identifies the first physical input. All other bits are reserved for future use and must be written as 0, and ignored when read.

For C4, this field may take the values 0, 1, 2, and 3.

Transition

The Transition field specifies when (i.e. under which conditions/circumstances) this particular instruction shall be executed.

Flag	Bit(s)	Description
HasAlternate	#7 (0x80)	When this bit is set, there is another instruction that shall be executed in alternating order with the current one, each time the other conditions are met. In this case two entries must exist, one with the Alternate bit clear, and one with the Alternate bit set.
Alternate	#6 (0x40)	If this bit is set, this is the alternate instruction of a pair of two instructions which are executed in alternating order. If this flag is set, "HasAlternate" must be set as well.
RFU	#5#4 (0x30)	These bits are reserved for future use and must be written as 0 and ignored when read.
Initial State	#3...#2 (0x0C)	These bits indicate the initial state of the input: 00b: Ignore: Don't care 01b: Pressed: The input was initially active (for less than a second) 10b: Kept pressed: The input has initially been active (for more than a second) 11b: Released. The input was initially inactive
Final State	#1... #0 (0x03)	These bits indicate the final state of the input: 00b: Ignore: Don't care 01b: Pressed: The input is active (for less than a second) 10b: Kept pressed: The input is still active (for more than a second) 11b: Released. The input is inactive

The "don't care" states are no real states, but rather placeholders for any other state. At any given time the input is either released, pressed or kept pressed.

Endpoint

Identifies the source endpoint that will be used in the outgoing ZCL command frame. Notice, that you should only use an endpoint, which hosts a cluster with the appropriate cluster ID and role (client vs. server).

ClusterID

Specifies the cluster ID that will be used in the outgoing ZCL command frame. The cluster ID must be an "operational" cluster, according to ZCL definitions.

CommandTemplate

This is the template of a ZCL command frame payload, which will be sent to the target device once the instruction is selected for execution by the universal input logic unique to ZigBee devices. This can be a simple toggle command, or a more complex move or recall scene command, for example.

Notice that C4 will use its binding table to determine the target for the command. The command may be sent to one or more targets, each being a group (specified as a group address) or a single application instance (specified as IEEE EUI-64 address and endpoint number).

Examples

This the complete default configuration for C4, which assigns each input as a push-button (momentary, one stable position) to a corresponding on/off cluster instance on the primary, secondary, tertiary, and quaternary level control switch endpoint:

```

48      element type: 0x48 (raw data)
04 00   element count: 0x0004 (4 entries)

06      element #1: six bytes
00      InputAndOptions: 0x00
0D      Transition: released -> pressed
01      Source: Endpoint #1 (hosts primary on/off client cluster on C4)
06 00   Cluster ID: 0x0006 - on/off
02      ZCL Command Template: Toggle

06      element #2: six bytes
01      InputAndOptions: 0x01
0D      Transition: released -> pressed
02      Source: Endpoint #2 (hosts secondary on/off client cluster on C4)
06 00   Cluster ID: 0x0006 - on/off
02      ZCL Command Template: Toggle

06      element #3: six bytes
02      InputAndOptions: 0x02
0D      Transition: released -> pressed
03      Source: Endpoint #3 (hosts tertiary on/off client cluster on C4)
06 00   Cluster ID: 0x0006 - on/off
02      ZCL Command Template: Toggle

06      element #4: six bytes
03      InputAndOptions: 0x03
0D      Transition: released -> pressed
04      Source: Endpoint #4 (hosts quaternary on/off client cluster on C4)
06 00   Cluster ID: 0x0006 - on/off
02      ZCL Command Template: Toggle

```

Safety & Warnings

- DO NOT install the device with power applied.
- DO NOT expose the device to moisture.

Wiring Diagram

Notes for the diagrams:

L - terminal for live lead input

N - terminal for neutral lead input

K1, K2, K3, K4 - terminals for push buttons

COM - common terminal for grounding to the push buttons connected to the coupler

1) AC Powered

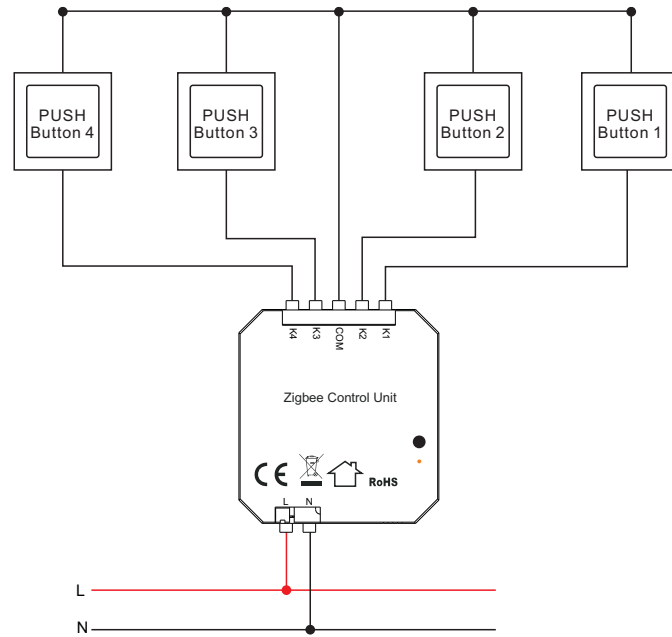

2) DC Powered

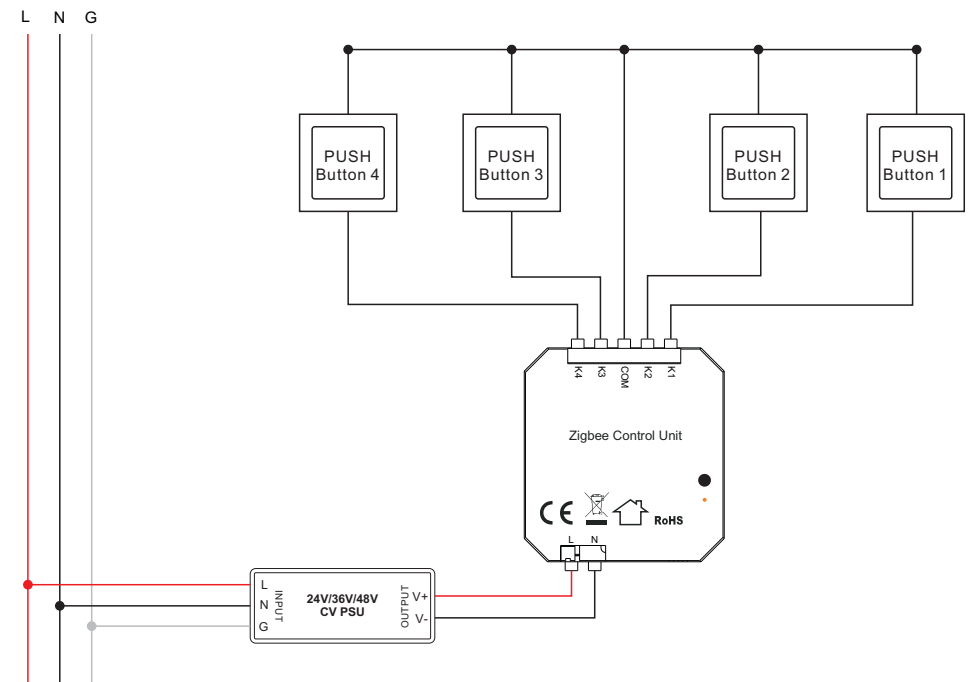

Note: 1) Number of push buttons connected to the coupler can be 1, 2, 3 or 4.

2) Supported switch types: 1-gang 1 way, 2-gang 1 way, 3-gang 1 way, 4-gang 1 way.